



SAFETY IS OUR TOP PRIORITY.

Whether in the chemical sector, energy production or in heavy industry: Wherever flammable substances are produced, processed, transported or stored, safety plays a particularly important role. Our recommendation for ATEX-certified, quality GIFAS products can be found in this chapter.

Labelling	216
Ex-Cable reels	218
Ex-Floodlights	220
Ex-Area lights	223
Ex-Tubular lights	224
Ex-Hand-held lights	225
Ex-Battery lights	227
Use cases	232



GAS

Electrical equipment for explosive gas atmospheres (Device group II [Chemistry])

EPL	Standards IEC/EN		Type of protection
Ga	60079-0		General requirements
	60079-11	ia	Intrinsic safety
	60079-18	ma	Encapsulation
	60079-26		Equipment with equipment protection level (EPL) Ga
	60079-28	op is	Protection of equipment and transmission systems using optical radiation
Gb	60079-1	d	Flame-proof enclosure
	60079-2	p, px, py	Pressurised enclosure
	60079-5	q	Powder-filled enclosure
	60079-6	o	Oil immersion
	60079-7	e	Increased safety
	60079-11	ib	Intrinsic safety
	60079-18	mb	Encapsulation
	60079-25		Intrinsically safe electrical systems
	60079-27		Fieldbus intrinsically safe concept (FISCO)
	60079-28	op is op pr op sh	Protection of equipment and transmission systems using optical radiation
Gc	60079-11	ic	Intrinsic safety
	60079-18	mc	Encapsulation
	60079-15	nA	Type of protection «non-sparking»
	60079-15	nR	Steam cover
	60079-15	nL	Limited energy (old edition only)
	60079-15	nC	Sparking apparatus
	60079-2	pz	Pressurised enclosure
	60079-28	op is op pr op sh	Protection of equipment and transmission systems using optical radiation

DUST

Electrical apparatus for use in the presence of combustible dust (Device group III)

EPL	standards IEC/EN		Type of protection
Da	60079-0		General requirements
	60079-31	ta	Protection by enclosures
	60079-11	ia	Protection by intrinsic safety (iaD IEC/EN 61241-11)
	60079-18	ma	Protection by encapsulation
Db	60079-31	tb	Protection by enclosures
	60079-11	ib	Protection by intrinsic safety (ibD IEC/EN 61241-11)
	60079-18	mb	Protection by encapsulation
Dc	61241-4	pD	Protection by excessive pressure 'pD'
	60079-31	tc	Protection by enclosures
	60079-11	ic	Protection by intrinsic safety
	60079-18	mc	Protection by encapsulation

Marking according to directive 94/9/EG (ATEX 95)

Identification number of the notified body (responsible for quality assurance)	Category zones
0102 Physikalisch-Technische Bundesanstalt PTB, Germany	1 zones 0 / 20
0158 DEKRA EXAM GmbH, Germany	2 zones 1 / 21
0032 TÜV CERT-Zertifizierungsstelle, Germany	3 zones 2 / 22
0344 KEMA N.V., Netherlands	
0081 LCIE Laboratoire Central des Industries Electriques, France	
0080 INERIS, France	G = Gas
1180 BASEEFA, Great Britain	D = Staub (Dust)
1258 Electrosuisse SEV, Switzerland	



Marking according EN 60079-0

Equipment groups (Gas)	
IIA	Acetone, ethane, benzene, automotive gasoline, butane, propane, methane
IIB	Ethylene, town gas
IIC	Hydrogen, acetylene

Temperature class	Max. surface temperature
T1	< 450 °C
T2	< 300 °C
T3	< 200 °C
T4	< 135 °C
T5	< 100 °C
T6	< 85 °C

Ex d IIC T5 Gb

EPL	Standards IEC/EN	Type of protection
Ga	60079-11	ia Intrinsic safety
	60079-18	ma Encapsulation
Gb	60079-1	d Flame-proof enclosure
	60079-2	p, px, py Pressurised enclosure
	60079-7	e Increased safety
	60079-11	ib Intrinsic safety
	60079-18	mb Encapsulation
Gc	60079-15	nA Type of protection "non-sparking"
	60079-15	nR Steam cover
	60079-2	pz Pressurised enclosure

zone	Equipment protection level (EPL)
0	Ga
1	Gb and Ga
2	Gc, Gb and Ga

Surface temperature (see EN 60078-0)

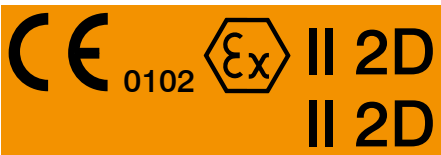

Ex tD A21 IP68 T95°C
Ex tb IIIC T95°C Db

EPL	Standards IEC/EN	Type of protection
Da	60079-31	ta Protection by enclosures
	60079-11	ia Protection by intrinsic safety
	60079-18	ma Protection by encapsulation
Gb	60079-31	tb Protection by enclosures
	60079-11	ib Protection by intrinsic safety
	60079-18	mb Protection by encapsulation
	61241-4	pD Protection by excessive pressure
Gc	60079-31	tc Protection by enclosures
	61241-4	pD Protection by excessive pressure

Equipment groups (Dust)	
IIIA	Fibres
IIIB	non-conductive dust
IIIC	Conductive dust

Zone	Equipment protection level (EPL)
20	Da
21	Db and Da
22	Dc, Db and Da

IP	First digit (against ingress of solid foreign bodies/against access to hazardous parts) =	Second digit (against ingress of water with damaging effects)
4	≥ 1.0 mm diameter	Splash-proof
5	Dust-proof	Water jet
6	Dust-tight	Strong water jet
7		Temporary immersion
8		Continuous immersion



502 series



Plug connectors from STAHL



Plug connectors from CEAG



Plug connectors from ATX
Illustration similar

Product features

- Solid rubber cable reel in EX design
- Suitable for zone 1 and 2
- Zinc-plated steel tube frame, black powder-coated with brass feet
- Design with K2 and EX labelling
- With warning notice
- "Using the cable reel in an environment at risk of explosion of gas group IIC is only permitted if the cable is first connected or the cable reel is standing on a conductive base or conductive and earthed base."
- High mechanical stability
- Impact-resistant and ageing-resistant
- Internal wedge brake
- Maintenance-free
- Resistant to chemical influences
- Resistant to oils and acids
- UV and weather resistant

Technical data 502-EX STAHL

Labelling	⊕ II 2 G, CE 0102
Explosion protection	EEX de IIC, IIB, T6
Test report	PTB Ex 04-14334
EC type approval certificate	PTB 03 ATEX 1186
Protection category	IP54
Sim. factor	1
Weight	approx. 13kg
Measurements	300x410x230 mm

Technical data 502-Ex CEAG

Labelling	⊕ II 2 G, CE 0102
Explosion protection 400V	EEX de IIC, IIB, T6
230V	EEX de IIC, IIB, T6
Test report	PTB Ex 04-14078
EC type approval certificate	PB03 ATEX 1186 G4
Protection category	IP54
Sim. factor	1
Weight of 502 Ex 400V/16A	approx. 13kg
502 Ex 230V/16A	approx. 18kg
Measurements	300x410x230 mm

Technical data 502-Ex ATX

Labelling	⊕ II 2 G, CE 0102
Explosion protection	EEX de IIC, IIB, T6
Test report	PTB Ex 04-14078
EC type approval certificate	PB03 ATEX 1186 G4
Protection category	IP54
Sim. factor	1
Weight of 502 30 m PROFLEXX-07	approx. 13kg
502 50 m PROFLEXX-07	approx. 18kg
Measurements	300x410x230 mm

Safety precautions

Always read the label on the cable reel before use!

Cable reel 502Ex is not suitable for zones 0, 20, 21 and 22. The temperature class and ignition protection classes specified on the equipment must be complied with. In order to avoid the non-permitted heating of cables, particularly while coiled, the maximum loads specified must not be exceeded.

The use of cable reel 502Ex in explosion group IIC is only permitted if the cable is first connected or the cable reel is standing on a conductive base or conductive and earthed base. Otherwise, the cable reel can be used in all zones only in explosion group IIA and IIB. No modifications or alterations must be made to the cable reels. The cable reels must only be operated in undamaged condition.

Note national safety and accident prevention regulations.

Spare parts

No individual or spare parts are supplied for safety reasons. Professional repairs with recorded final checks must only be carried out at the manufacturer's.

Item no.	Description
251152	502-Ex STAHL, input 30m GIFAS-PROFLEXX-07 cable 5x2.5mm ² CEE connector 5x16A/400V, output 1 CEE plug socket 5x16A/400V, no fuse
251137	502-Ex STAHL, input 30m GIFAS-PROFLEXX-07 cable 3x2.5mm ² CEE connector 3x16A/230V Output 1 CEE plug socket 3x16A/230V
247373	502-Ex CEAG, input 30m GIFAS-PROFLEXX-07 cable 5x2.5mm ² CEE connector 5x16A/400V, output 1 CEE plug socket 5x16A/400V, no fuse
247389	502-Ex CEAG, input 50m GIFAS-PROFLEXX-07 cable 3x2.5mm ² CEE connector 3x16A/230V Output 1 CEE plug socket 3x16A/230V
248070	502-Ex CEAG, input 50m GIFAS-PROFLEXX-07 cable 3x2.5mm ² , CEE connector 3x16A/230V, output 1 CEE plug socket 3x16A/230V, no fuse
280088	502-Ex ATX, input 30 m GIFAS-PROFLEXX-07 cable 3 x 2.5 mm ² , CEE plug 16 A/230 V, ATX 097433, output 1 CEE plug socket 3 x 16 A/230 V, no fuse, Fabr. ATX 097413
280089	502-Ex ATX input 50 m GIFAS-PROFLEXX-07 cable 3 x 2.5 mm ² , CEE plug 16 A/230 V, ATX 097433 Output 1 CEE plug socket 3 x 16 A/230 V, no fuse, Fabr. ATX 097413

Versions with other cable lengths or plug connections from STAHL are possible.

Series 518



Plug connectors from STAHL



Plug connectors from CEAG

Product features

- EX solid rubber cable drum as per DIN 14680-A1
- Made from zinc-plated sheet steel with powder coating in RAL 5002 (blue) with solid rubber carrying handle
- Velcro strip for lateral fastening of the plug
- Rotating auxiliary drum
- Without slip rings and thermal overload protection
- Brass feet for low earth contact resistance and spark protection
- For explosion-risk areas Zone 1, Zone 2
- High mechanical stability
- Impact-resistant and ageing-resistant
- External, maintenance-free parking brake
- Resistant to chemical influences
- Resistant to oils and acids
- UV and weather resistant

Technical data 518-Ex STAHL

Labelling	⊕ II 2 G, EEx de IIA T6
Explosion protection	EEx de IIA T6
Test report	PTB Ex 06-16168
EC type approval certificate	PTB03 ATEX 1186
Protection category	IP65
Sim. factor	1
Weight of 518 Ex 230V/16A	approx. 24kg
518 Ex 400V/16A	approx. 30kg
Measurements	512x380x310mm

Technical data 518-Ex CEAG

Labelling	⊕ II 2 G, EEx de IIA T6
Explosion protection	EEx de IIA T6
Test report	PTB Ex 06-16168
EC type approval certificate	PTB03 ATEX 1186
Protection category	IP65
Sim. factor	1
Weight of 518 Ex 230V/16A	approx. 24kg
518 Ex 400V/16A	approx. 30kg
Measurements	554x380x310mm

Safety instructions

Always read the label on the cable reel before use!

Cable reel 518 Ex is not suitable for zones 0, 20, 21 and 22. The temperature class and ignition protection classes specified on the equipment must be complied with. In order to avoid the non-permitted heating of cables, particularly while coiled, the maximum loads specified must not be exceeded.

No modifications or alterations must be made to the cable reels. The cable reels must only be operated in undamaged condition. Also note national safety and accident prevention regulations.

Standards Conformity

- Underlying safety and health requirements satisfied by EN 5000141997 + A1 + A2, EN 5000182000, EN 500192000.
- Correspond to the Directive of the European Council 94/9 EC
- Produced and tested in accordance with the manufacturer standards DIN EN 603092000, DIN EN 612421997 and DIN EN 613162000

Spare parts

No individual or spare parts are supplied for safety reasons. Professional repairs with recorded final checks must only be carried out at the manufacturer's.

Item no.	Description
261750	518-Ex STAHL input 5m GIFAS-PROFLEXX-07 cable H07RN-F 3x2.5mm ² with Ex connector 3x16A/230V Output 45m GIFAS-PROFLEXX-07 cable H07RN-F 3x2.5mm ² with Ex coupling 3x16A/230V
261751	518-Ex STAHL input 5m GIFAS-PROFLEXX-07 cable H07RN-F 5x2.5mm ² with Ex connector 5x16A/400V Output 45m GIFAS-PROFLEXX-07 cable H07RN-F 5x2.5mm ² with Ex coupling 5x16A/400V
247636	518-Ex CEAG input 5m GIFAS-PROFLEXX-07 cable H07RN-F 3x2.5mm ² with Ex connector 3x16A/230V Output 45m GIFAS-PROFLEXX-07 cable H07RN-F 3x2.5mm ² with Ex coupling 3x16A/230V
247886	518-Ex CEAG input 5m GIFAS-PROFLEXX-07 cable H07RN-F 5x2.5mm ² with Ex connector 5x16A/400V Output 45m GIFAS-PROFLEXX-07 cable H07RN-F 5x2.5mm ² with Ex coupling 5x16A/400V

! Certified quality guaranteed
GIFAS Ex products are used wherever there is a risk of explosion.

FlutLED-Ex 60W



FlutLED-Ex 60W is suitable for all areas that require efficient and extremely robust Ex-safe lighting with outstanding illumination. Areas of application include refineries, on drilling platforms, in the energy and chemical industry, in fire-fighting, in disaster protection, in tunnels and in ports.

Product features

- Thanks to their compact shape, the FlutLED-Ex 60W are especially suitable for use in small and confined spaces
- Reduced dazzle thanks to anti-glare surface, making them especially suitable for applications involving direct visual contact with the light source
- Casing made from highly stable aluminium alloy for applications in corrosive environments
- Shock and vibration-resistant, hardened glass reduces the risk of premature failure
- Explosion-protected, fire-resistant, water and salt water resistant, dust-proof

Technical data

Labelling	Ex II 2 G - Ex d IIC T5 Gb Ex II 2 D - Ex t IIIIC T95°C Db
Ex zones	1, 2, 21 and 22
Input voltage	24~48VAC/DC or 100~277VAC (50/60Hz)
Light source	OSRAM LED
System performance	60W
Light current	6600lm
System efficiency	110lm/W
Light colour	average 6000K
CRI-index	Ra >80
Beam angle	80° or 120°
Operating life	>50,000h
Protection category	IP66
Protection class	I
Operating range of temperature	-40° to +55°C
Housing	Pressure die-cast aluminium
Cover	Glass
Weight	approx. 3.5kg
Measurements (HxD)	206x220mm

Item no.	Description
800019	FlutLED-Ex/W60V230/80°
800020	FlutLED-Ex/W60V230/120°
800021	FlutLED-Ex/W60V24~48VAC/DC/80°
800022	FlutLED-Ex/W60V24~48VAC/DC/120°
800034	FlutLEDEx/W60.bracket
800035	FlutLEDEx/W60.bracket cable assembly
800036	FlutLEDEx/W60.swivel bracket
800037	FlutLEDEx/W60.safety grille

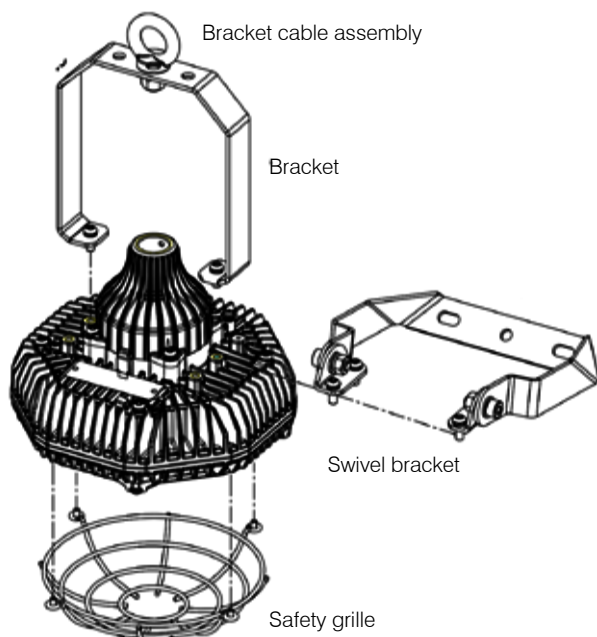

Beam angle 80°

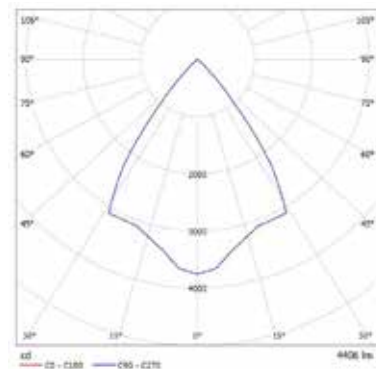

Beam angle 120°

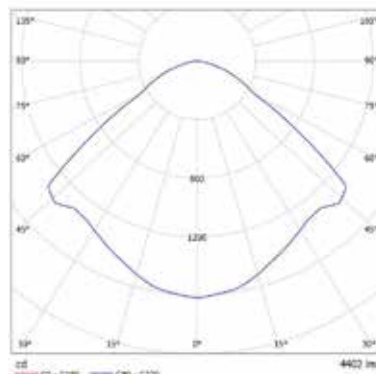

FlutLED-Ex 120W / 150W



Technical data

Labelling	⊕ II 2 G - Ex d e IIB T5 Gb ⊕ II 2 D - Ex t III C T95°C Db
Ex zones	1, 2, 21 and 22
Input voltage	180~277VAC (50/60Hz)
Light source	SEOUL SMD-LEDs
System performance	120W/150W
System efficiency	120lm/W
Light colour	average 6000K
Operating life	> 50,000h
Protection category	IP66
Operating range of temperature	-40°C to +55°C
Weight	13.5kg
Measurements (WxDxØ)	426x187x410 mm

FlutLED-Ex 120W and 150W are suitable for all areas that require efficient and extremely robust Ex-safe lighting. With their excellent illumination, these Ex lights are used in refineries, the energy and chemical industry, on drilling platforms, in fire-fighting, in disaster protection and also as stadium lighting.

Product features

- Excellent efficiency and high light yield thanks to 90 LEDs
- Reduced dazzle with direct visual contact thanks to anti-glare coating on the glass cover
- Shock and vibration-resistant thanks to hardened glass
- Robust aluminium casing with anti-corrosion paint
- Optional and optimised light distribution for various applications

Item no.	Description
288409	FlutLED-Ex 120W 60°
288410	FlutLED-Ex 120W 120°
281816	FlutLED-Ex 150W 60°
281817	FlutLED-Ex 150W 120°
Accessories	
281898	Holding bracket
281899	Swivel bracket*
282044	Pole mount bracket
281900	Hanging ring
281901	Spacer
281902	Safety grille

* Essential accessory 281899 swivel bracket

Beam angle of FlutLED 120W, 60°

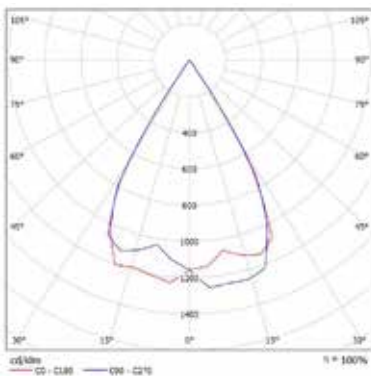

Beam angle of FlutLED 120W, 120°

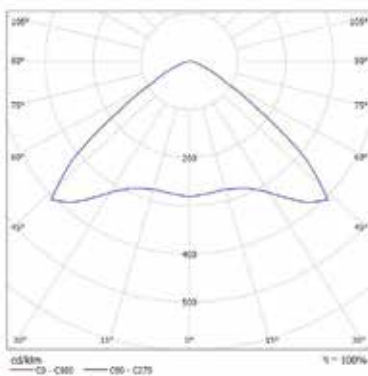

Beam angle of FlutLED 150W, 60°

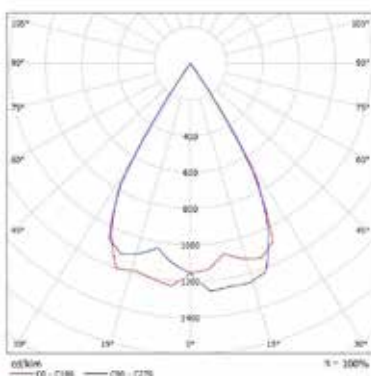

Beam angle of FlutLED 150W, 120°

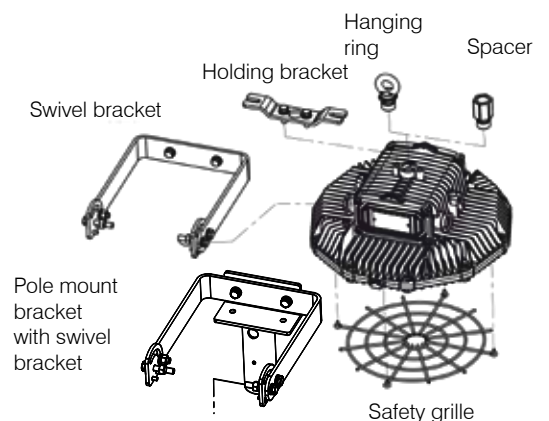
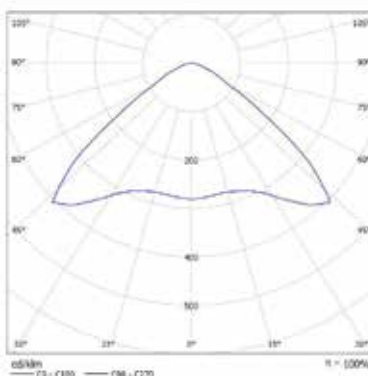

Supplied state:
The light comes without accessories as standard!



FlutLED-Ex battery 10W



Portable Ex floodlight for flexible applications Easy to attach, bright light, robust design

Product features

- Flexible mounting onto metal surfaces thanks to integrated magnetic field in the lamp base
- Transportable, handy design
- Bright light
- Shock and vibration-resistant thanks to hardened glass
- Robust aluminium casing with anti-corrosion paint
- Satisfies requirements for emergency lighting (discharge time > 10h)

Technical data

Labelling	<ul style="list-style-type: none"> Ex II 2 G Ex d IIC T6 Gb Ex II 2 G Ex tb IIIC T80°C Db
Ex zones	1, 2, 21 and 22
Input voltage	100-277VAC (50/60Hz)
Power supply	Li-ion battery
Charging time	4.5 hours
Light duration	max. 10h
Light source	SEOUL SMD-LEDs
System performance	10W
System efficiency	1265lm
Light colour	average 6000K
Operating life	> 50,000h
Protection category	IP66
Operating range of temperature	-20°C to +40°C
Weight	5.3kg
Measurements	210x182x282mm

Item no.	Description
288400	FlutLED-Ex battery 10W

Beam angle

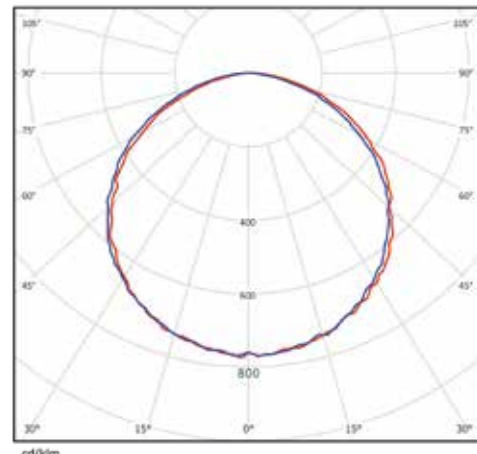

Ex strip luminaire 36W / 56W



The Ex strip luminaire is suitable for all areas that require efficient and extremely robust Ex-safe lighting. The robust aluminium casing can withstand forces of up to 10 Joule. The high IP66 protection category makes this light suitable for even the most challenging of locations, and ensures it is able to withstand even corrosive applications and salt water.

Item no.	Description
800023	Ex strip luminaire 36W 120°, incl. mounting bracket
800024	Ex strip luminaire 56W 120°, incl. mounting bracket

Technical data

Labelling	II 2 G Ex d eb IIB T6 Gb II 2 D Ex tb IIIC T80°C Db
Ex zones	1, 2, 21 and 22
Input voltage	100~277VAC (50/60Hz)
Light source	SEOUL SMD-LEDs
System performance	36/56W
Light current	36W: 4554lm 56W: 7084lm
Light colour	average 6000K
Operating life	>50,000h
Protection category	IP66
CRI-Index	Ra > 80
Operating range of temperature	-40°C to +55°C
Weight	36W: 6.4kg 56W: 8.7kg
Measurements (WxHxL)	36W: 187x80x600mm 56W: 187x80x1130mm

Beam angle

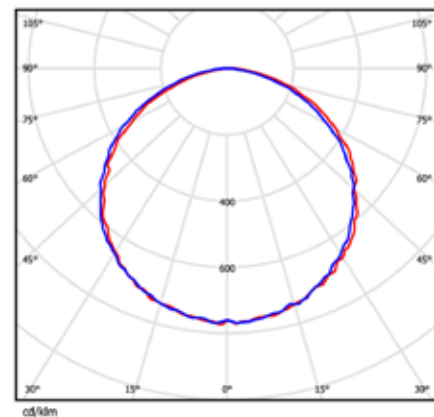

LED

High-quality LEDs are used in the GIFAS Ex luminaire range that are ideal for use in terms of light quality, service life, light colour and efficiency.

Ex machine light LED



Ex-protected machine light with LED technology, especially for local lighting of spaces and machinery or their sub-areas in explosion-risk areas of zones 1 and 2 as well as 21 and 22.

Product features

- High-efficiency LED technology
- Extremely long service life
- No bulb change required at any point in the light's lifetime
- Various operating voltages
- Robust protective tube made from polycarbonate

Technical data

Labelling	II 2 G Ex d IIC T5 Gb II 2 D Ex tb IIIC T95°C Db
EC type approval certificate	BVS 07 ATEX E 164 X
International approval	IECEX BVS 08.0014 X
Protection category	IP68 (2.5 m over 24 hours)
Operating range of temperature	-20°C to +60°C
Standard connection	Cable 5 m 3x 1 mm ² , without plug

Item no.	Voltage	A (mm)	B (mm)	C (mm)	Weight
287678	12-24 VDC-6W,	581	43	66	Approx. 1.5 kg
288882	24-50 VAC/DC-6W	581	43	66	Approx. 1.5 kg
286926	120-264 VAC/DC-6W	581	43	66	Approx. 1.5 kg
287692	85-265 VAC-25W	1601	60	82	Approx. 4.0 kg
287693	85-265 VAC-36W	1901	61	82	Approx. 4.1 kg

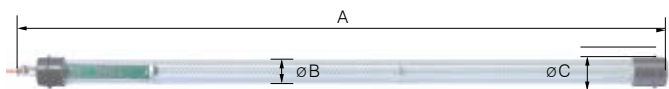

Accessories for wall mounting available on request!

Ex hand-held lights LED



Ex-protected hand-held lights with LED technology, especially for inspection and maintenance work in explosion-risk areas of zones 1 and 2 as well as 21 and 22.

Product features

- High-efficiency white LED technology
- Extremely long service life
- No bulb change required at any point in the light's lifetime
- Various operating voltages
- Robust protective tube made from polycarbonate

Technical data

Labelled according to 94/9/EC	II 2 G Ex d IIC T5 Gb II 2 D Ex t IIIC T95°C Db
EC type approval certificate	BVS 07 ATEX E 164 X
International approval	IECEX BVS 08.0014 X
Protection category	IP68 (2.5 m over 24 hours)
Operating range of temperature	-20°C to +60°C
Standard connection	Cable 5 m 3x 1 mm ² , without plug

Item no.	Voltage	Weight
287634	12-24 VDC-6W	Approx. 1.5 kg
288883	24-50 VAC/DC-6W	Approx. 1.5 kg
288884	120-264 VAC/DC-6W	Approx. 1.5 kg

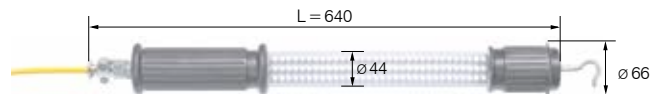

Accessories

Magnetic clamp
Permanent magnet (different magnetic force), hose clip with stainless steel 1.4301 ball (type PM1) or corresponding extension (type PM2).

Item no.	Description	Weight
288885	PM 1 10 kN Ø approx. 45 mm, A = 130 mm	Approx. 0.18 kg
288886	PM 2 50 kN Ø approx. 60 mm, A = 215 mm	Approx. 0.68 kg
288887	PM 2 50 kN Ø approx. 70 mm, A = 225 mm	Approx. 0.68 kg

Other options available on request.

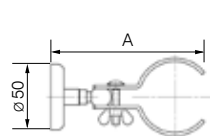

Type PM 1

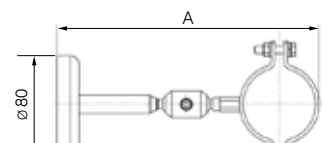

Type PM 2

FlashLED-Ex Rechargeable battery light



The tried-and-tested FlashLED concept is now also available for areas at risk of explosion! As a result, GIFAS is offering a powerful work and inspection light with emergency light function for explosive areas. The FlashLED-Ex is equipped with an environmentally friendly, rechargeable lithium polymer (LiPo) battery. The light is charged outside the explosion-risk area. The FlashLED-Ex is certified and satisfies the requirements of the European Low-Voltage Directive 2006/95/EC, Directive 2004/108/EC on Electromagnetic Compatibility and ATEX Directive 94/9/EC.

Product features

- Sturdy, shatter-proof polyamide housing
- Up to 8 hours of light in three selectable operating modes
 - Broad beam concentrated, narrow and wide light beam
 - Work light (emergency light) broad light cone
 - Side light space-illuminating economy light
- Extremely bright light
- incl. charger with corrosion-resistant contacts
- Charging station can be used as a wall-mounted model
- Overcurrent, temperature and deep discharge protection
- Vertical-swivel lamp head, dimmable, flash mode
- Memory function = last setting is saved
- The light can be locked in the charging station (shackle lock not included in the scope of delivery)

Technical data

Labelling	⊕ II 2G Ex ib IIC T4 Gb ⊕ II 2D Ex ib III C T135°C Db
Certification	2004/108/EC Directive on Electromagnetic Compatibility ATEX Directive 2014/34/EU DEKRA 12ATEX0193X
ATEX Certification No.	
EX zones	1, 2, 21 and 22
Input voltage	230VAC, 12/24VDC
Power supply	Lithium polymer rechargeable battery
Charging time	6.5 hours
Light duration	max. 8h, depending on type of operation
Light source	5x1,6W Power LEDs, white
Protection category	IP65
Operating range of temperature	-20°C < Ta < +50°C
Temperature class	T4
Gas group	IIC
Dust group	IIIC
Weight	
- Light	1.4kg
- Charging station	700g
Measurements (WxHxD)	
- Light excl. charging station	125x260x92.5mm
- Light incl. charging station	149x332x106mm
- Charging station	149x276x95mm

Item no.	Description
800011	FlashLED-EX rechargeable hand-held light
860032	Charger / wall bracket 230V
860027	Charger / wall bracket 12/24V
266884	Charging cable 12/24V
266850	Carrying strap



Wall fitting

TorchLED-Ex torch light



The popular TorchLED work and inspection luminaire with emergency lighting function is now also available in an Ex-version. The luminaire is equipped with a rechargeable lithium polymer (LiPo) battery has to be charged outside the ex-zone. The TorchLED Ex fulfils the requirements of the Low Voltage Directive 2006 / 95 / EC, the Directive 2004 / 108 / EC concerning electromagnetic compatibility and the ATEX Directive 94 / 9 / EC.

Product features

- at least 3 hours of light in three selectable operating modes:
 1. Spot: Focussed, narrow and broad light beam
 2. Wide: Room illuminating light
 3. High beam: Widely radiating beam of light
- memory function (last setting is retained)
- corrosion-resistant charging pins (gold-plated spring steel)
- overcurrent, temperature and deep discharge protection
- compact design



Item no. 860444



Item no. 860443

Technical Data

TorchLED Ex

Housing colour	black
Operating voltage	6VDC
Electric power supply	LiPo 7.4V - 720mAh
Charging time	6.5h
Light duration factory settings (max. light power)	
- Spot (1 LED)	6h
- Wide (1 LED)	6h
- Full light (2 LED)	3h
- Emergency light	5h
Illuminant	2 Power-LED à 1.6W, cool white 5700 K
Protection category light	IP54
Dimensions (W×L×H)	
- Light excl. charging station	116×68×34 mm
- Light incl. charging station	148×87×44 mm
Weight light	165 g
ATEX certification number	KIWA 16ATEX0035X
Explosion-proof according to	EN 60079-02009 (general requirements) EN 60079-112012 (intrinsic safety)
Zones	1, 2, 21 and 22
Permitted ambient temperature	-20° C < Ta < +45° C
Markinig	II 2 G Ex ib IIC T4 Gb II 2 D Ex ib IIC T140° C Db

Charging station

Protection category	IP44
Protection class 230 VAC	II
Protection class 12-48VDC	III
Dimensions (L×W×H)	87×82×34 mm
Weight 12-48V/230V	70g/80g
Permitted ambient temperature	0° C to +40° C

Item no.	Description
860454	TorchLED Ex torch light 6VDC, excl. charging station
Accessories	
860443	TorchLED charging station 230 VAC, incl. 1,5 m cable and euro-plu
860444	TorchLED charging station 12-48 VDC, with 1,5 m cabl

PARALUX PX0



Product features

- ATEX certified for ZONE 0 and dust Ex ZONE 21
- 100% watertight
- Made from high-resistance conductive plastic, offers additional protection as per ESD/EMI/RFI
- Compatible with virtually all helmet brackets and PARASNAP
- Rubberised lamp head
- Push switch at the end of the lamp for single-handed operation

Technical data

Labelling	⊕ II 1G Ex ia IIC T4 Ga ⊕ II 2D Ex ib IIIC T105°C Db IP68
Ex zones	0, 21
Light source	3W CREE LED, white
Batteries	4xAA alkaline
Light current	120lm
Light range	150m
Light duration	15h full power 50h total
Protection category	IP68
Housing	XAG (plastic), red
Measurements (HxL)	38x167mm
Weight incl. batteries	170g

Item no.	Description
283286	PARALUX PX0 incl. batteries

PARALUX PX1



Product features

- ATEX certified for ZONE 1 and dust Ex ZONE 21
- 100% watertight
- Made from non-conductive plastic
- Compatible with virtually all helmet brackets and PARASNAP
- Rubberised lamp head
- Push switch at the end of the lamp for single-handed operation

Technical data

Labelling	⊕ II 2G Ex ib IIB T4 Gb ⊕ II 2D Ex ib IIIC T105°C Db IP68
Ex zones	1, 21
Light source	3W CREE LED, white
Batteries	4xAA alkaline
Light current	120lm
Light range	150m
Light duration	15h full power 50h total
Protection category	IP68
Housing	PC (polycarbonate), yellow
Measurements (HxL)	38x167mm
Weight incl. batteries	170g

Item no.	Description
283285	PARALUX PX1 incl. batteries

PARALUX PX2



Product features

- ATEX certified for ZONE 1
- 100% water-tight
- Made from non-conductive plastic
- Fastening clip
- Compatible with PARASNAP
- Rubberised lamp head
- Push switch at the end of the lamp for single-handed operation

Technical data

Labelling	Ⓔ II 2G Ex ib IIB T4 Gb
Ex zone	1
Light source	1W CREE LED, white
Batteries	2xAAA alkaline
Light flux	30lm
Light range	35m
Light duration	10h
Protection category	IP68
Housing	PC (polycarbonate), yellow
Measurements (HxL)	19x143mm
Weight incl. batteries	40g

Item no.	Description
283284	PARALUX PX2 incl. batteries

PARALUX HL-P1
Head light



Product features

- ATEX certified for ZONE 1
- 100% water-tight
- Made from non-conductive plastic
- Adjustable rubber / Neoprene strap
- Rubberised lamp head with incrementally adjustable beam angle
- Push switch for single-handed operation

Technical data

Labelling	Ⓔ II 2G Ex ib IIB T4 Gb
Ex zones	1
Light source	3W CREE LED, white
Batteries	4xAAA alkaline
Light flux	120lm
Light range	150m
Light duration	12h full power 45h total
Protection category	IP68
Housing	PC (polycarbonate), yellow
Measurements (HxL)	65x70mm
Weight incl. batteries	170g

Item no.	Description
283287	PARALUX HL-P1 incl. batteries

PARASNAP SNAP-IN1
Lamp holder



Product features

- Fastening clip for PX0 and PX1
- Magnetic counterpiece to PARASNAP PRO BASE left/right
- The holder is simply folded onto the side of the lamp body

Technical data

Material	Fibreglass-reinforced polyamide
Measurements	50x40mm
Weight	11g

Item no.	Description
283290	PARASNAP SNAP-IN1

PARASNAP SNAP-IN2
Lamp holder



Product features

- Fastening clip for PX2
- Magnetic counterpiece to PARASNAP PRO BASE left/right
- The holder is simply pushed from behind over the lamp body

Technical data

Material	Fibreglass-reinforced polyamide
Measurements	35x30mm
Weight	10g

Item no.	Description
283291	PARASNAP SNAP-IN2

PARASNAP PRO BASE LEFT
Helmet mounting



Product features

- Helmet mounting, base part for left-handed wearing
- Left-hand base holder for PX1 and PX2
- SNAP-IN1 (PX0, PX1) or SNAP-IN2 (PX2) is also required
- Can be mounted on virtually all common DIN helmet types
- Certification based on DIN EN 433:2008 for helmets:
Dräger HPS 4300, Schubert F120 pro/ F130, Colsman AL-EX
(Rosenbauer HEROS smart&titan, Dräger HSP 4500 on rdemand)

Technical data

Material Polyamid, PA 66
Measurements 65x55x45mm
Weight 50g

Item no.	Description
283288	PARASNAP PRO BASE left

PARASNAP PRO BASE RIGHT
Helmet mounting



Product features

- Helmet mounting, base part for right-handed wearing
- Left-hand base holder for PX1 and PX2
- SNAP-IN1 (PX0, PX1) or SNAP-IN2 (PX2) is also required
- Can be mounted on virtually all common DIN helmet types
- Certification based on DIN EN 433:2008 for helmets:
Dräger HPS 4300, Schubert F120 pro/ F130, Colsman AL-EX
(Rosenbauer HEROS smart&titan, Dräger HSP 4500 on rdemand)

Technical data

Material Polyamid, PA 66
Measurements 65x55x45mm
Weight 50g

Item no.	Description
283289	PARASNAP PRO BASE right

PARASNAP BASE
Strap holder



Product features

- Strap holder made from cow leather
- SNAP-IN1 (PX0, PX1) or SNAP-IN2 (PX2) is also required
- Strap opening width up to 55 mm

Technical data

Material Cow leather and fibreglass-reinforced polyamide
Measurements 90x70mm
Weight 35g

Item no.	Description
283292	PARASNAP Base strap holder

PARASNAP Strap
Safety helmet



Product features

- Mounting strap for safety helmet mounting
- SNAP-IN1 (PX0, PX1) or SNAP-IN2 (PX2) is also required
- compatible mit PX0, PX1, PX2

Technical data

Material Polyamid, EPDM
Measurements Base 35x60mm
Weight Base 60g

Item no.	Description
290110	PARASNAP Strap

MITYLITE 1965Z0 LED



When you need the latest and brightest LED technology in a compact form factor, choose the new MITYLITE1965Z0 LED. Small enough to fit in your shirt pocket, yet bright enough to illuminate your work area. Long lasting, energy efficient, bright LEDs, along with a compact package make the MITYLITE1965Z0 LED the safety approved light for the job.

Product features

- Rotary switch on lamp head
- ATEX approved
- Spring clip allows the light to be easily attached

Technical data

Labelling	Ex II 1 GD Ex ia IIC T4 Ga Ex iaD 20 IP65 T90°C Da TRAC10ATEX11241X
IECEX labelling	IECEX TRC10.0005X II 1 GD Ex ia IIC T4 Ga Ex iaD 20 IP65 T90
Ex zone	0, 20
Housing	ABS (neon yellow)
Light source	LED
Light duration	Approx. 4h
Light range	Approx. 50m
Batteries	2xAAA alkaline
Length	139mm
Weight incl. batteries	90g

Item no.	Description
283367	Battery light MITYLITE 1965Z0 LED incl. batteries

3315Z0 LED



The 3315Z0 LED light the lightweight compact design houses 3AA batteries that power a single LED for 110 lumens of super bright LED light. Safety approved for the most volatile work environments ATEX Cat. 1 (Zone 0), the 3315Z0 LED light is one of the most efficient torches on the market today.

Product features

- Pressure switch at the lamp head
- Compact light with huge LED performance.
- ATEX approved
- Housing made from Anti Static ABS
- Light is resistant to corrosion and extreme temperatures
- Submersible

Technical data

Labelling	Ex II 1 G Ex ia IIC T4 Ga Ex II 1 D Ex ia IIC T130°C Da TRAC13ATEX0009X
Ex zone	0, 20
Light source	LED
Light duration	Approx. 19h
Light range	Approx. 160m
Batteries	3xAA alkaline
Length	156mm
Weight incl. batteries	130g

Item no.	Description
283369	Battery light 3315Z0 LED incl. batteries

**HEADS UP LITE 2755Z0 LED
Battery head and helmet light**



Bright, compact headlight for harsh conditions - the high output 2755Z0 LED Headlight provides up to 72 lumens of illumination, flashing, and low light modes. Designed with weather resistant casings which also allows for fast and easy battery change.

Product features

- Secure fastening and excellent wearing comfort thanks to adjustable textile head band
- Housing made from shock-resistant and chemical-resistant ABS
- Non-permeable to water
- ATEX approved
- Angled profile head button is failsafe and easy to operate, even with large gloves on

Technical data

Labelling	⊕ II 1 G Ex ia IIC T4 Ga TRAC13ATEX0035X
Ex zone	0
Light source	LED
Lighting current	74lm
Light duration	Approx. 6h (bright) Approx. 15h (low)
Light range	Approx. 60m
Batteries	3xAAA alkaline
Length	57mm
Weight incl. batteries	100g

Item no.	Description
283368	head/helmet light HEADS UP LITE 2755Z0 LED incl. batteries

**HEADS UP LITE 2690Z0/20 LED
Battery head and helmet light**



This battery head and helmet light is brighter, more efficient, compact and lighter than other headlamps in its class. The rotary bezel switch is easy to operate, even when wearing bulky gloves. The 2690Z0/20 is made of impact and chemical resistant ABS and it's water resistant for all-weather use. It comes with an adjustable and comfortable cloth strap, as well as a heavy duty rubber strap that will not slip off your helmet.

Product features

- Secure fastening and excellent wearing comfort thanks to adjustable textile head band
- Housing made from shock-resistant and chemical-resistant ABS
- Non-permeable to water
- ATEX-certified
- Angled profile head button is failsafe and easy to operate, even with large gloves on

Technical data

Labelling	⊕ II 1 D/G Ex ia IIC T4 ⊕ Ex iaD 20 IP65 T65°C
EC type approval certificate	TRL 08 ATEX 11184X
Ex zone	0, 20
Light source	LED
Lighting current	74lm
Light duration	10 hours
Batteries	3xAAA alkaline
Length	71mm
Weight incl. batteries	120g

Item no.	Description
268524	head/helmet light HEADS UP LITE 2690Z0/20 incl. batteries

Ex-Cable reels / Ex-Floodlights



Ex-Hand-held lights / Ex-Battery lights



WE ARE EXPERTS IN YOUR FIELD

Construction industry

Industrial sector

Safety equipment

Ex-Products

**Online products available
at www.gifas.de/en**

Find the suitable product
solution for you on our
website and read all the
latest news about our
products.

